

CPHD-1

High-Definition Multimedia Interface Pattern Generator Quick Guide

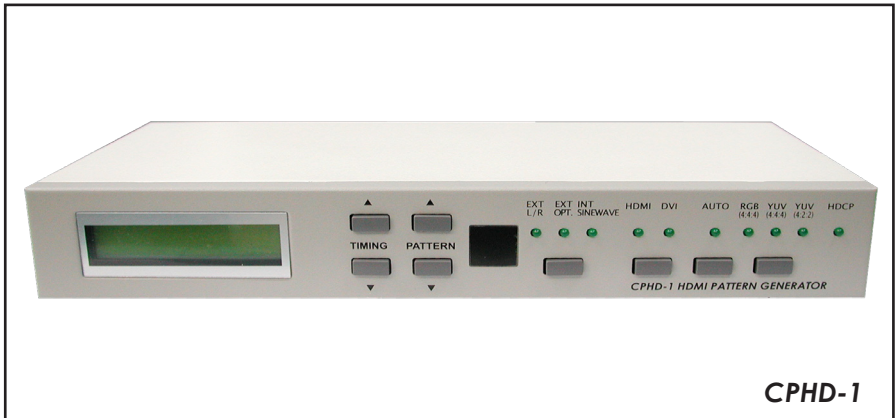

TABLE OF CONTENTS

1. Features and Specifications	3
Features	3
Specifications	3
RS-232 Protocol	3
2. Front Panel Operation	4
3. Rear Panel Installation and Connection	5
4. TIMING Table	6
5. PATTERN Table	7
6. Remote Control	12
7. RS-232 Remote Control Protocol.....	13
8. RS232 Remote Control Application.....	15
8.1 Main Window.....	15
8.2 Select COM port to control	15
8.3 Switch TIMING	16
8.4 Switch PATTERN	17
8.5 Programming TIMING/PATTERN	18
8.6 EDID	19
8.6.1 Read EDID	20
8.6.2 Memory of EDID	20
8.6.3 Upload EDID	20
8.6.4 Write EDID	20

1. Features and Specifications

Features

- Provides total 39 Timings and 39 Patterns
- Supports HDCP signal verification pattern (P39)
- On-panel LED display and LED indicators
- Remote control
- Supports RS-232 control, specific PC application included

Specifications

- HDMI v1.2, HDCP 1.1 and DVI 1.0 compliant
- HDMI Frequency bandwidth: 1.65Gbps (single link)
- Input: Audio L/R x 1 and Toslink S/PDIF x 1
- Output: HDMI female port (type A connector) x 1
- Power Supply: 5VDC 2.6A power supply (AC 90-240V)
- Weight: 1.5Kgs
- Dimensions: 280(W) x 130(D) x 44(H) mm

RS-232 Protocol

Pin	Definiton		Pin	Definition
1	NC		1	NC
2	TxD		2	RxD
3	RxD		3	TxD
4	NC	→	4	NC
5	GND	←	5	GND
6	NC		6	NC
7	NC		7	NC
8	NC		8	NC
9	NC		9	NC

2. Front Panel Operation

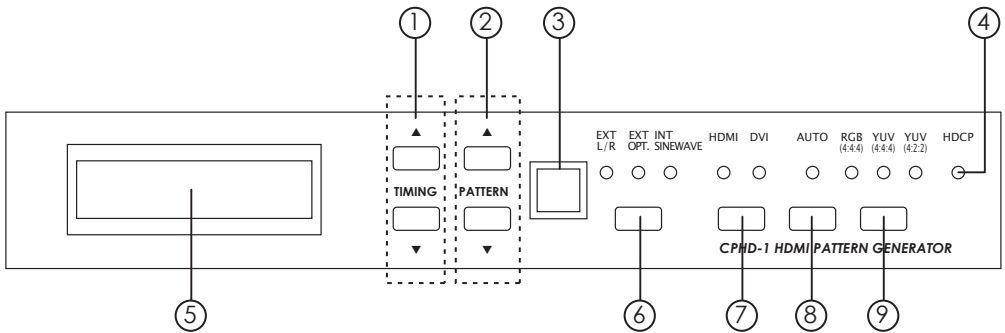

1. Pattern Selection:
From P01 ~ P39
2. Resolution/Freq. Selection:
From T01 ~ T39
3. Remote control sensor
4. HDCP LED Indicator:
The LED will illuminate when pattern "P39 HDCP-Produce" is selected and the output display (TV, monitor, etc.) supports HDCP. To unilluminate the HDCP indicator (Switch Off HDCP), first step to change to other pattern and then changed either Timing, HDMI/DVI output selection or color space selection.
5. Display of PATTERN/TIMING:
Upper line: Number of TIMING, Resolution and Frequency (Example: T01 640x480-60)
Lower line: Number of PATTERN and name of PATTERN (Example: P01 WHITE)
6. Audio Source Selection:
External L/R
External Optical
Internal Sinewave
7. HDMI/DVI Output Selection
8. Turn on/off AUTO pattern
random-cycling
9. Color Space Selection:
RGB 4:4:4
YUV 4:4:4
YUV 4:2:2

3. Rear Panel Installation and Connection

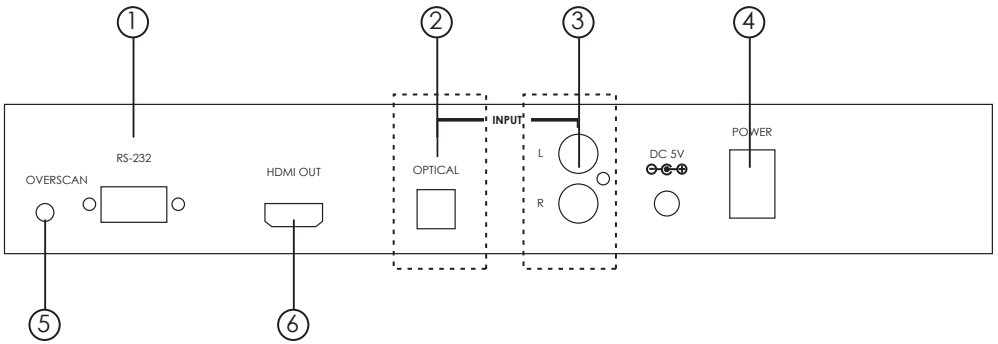

1. RS232 Communication Port:

Connect to the COM1 or COM2 port of your PC, and control the unit remotely using the application provided.

2. Audio Optical Input

3. Audio L/R Input

4. Power Switch

5. Fill-Screen Button:

For some modals of TV/monitor, the video signal can not fill the screen of display completely, to correct this problem, press the button once when the power is on.

6. HDMI OUT:

The HDMI output can be connected to a HDMI display using HDMI cable, or to a DVI display using HDMI to DVI cable.





5. TIMING Table

No.	Resolution	Frequency (Hz)
T01	640x480	60
T02	640x480	72
T03	640x480	75
T04	640x480	85
T05	800x600	56
T06	800x600	60
T07	800x600	72
T08	800x600	75
T09	800x600	85
T10	1024x768	60
T11	1024x768	70
T12	1024x768	75
T13	1024x768	85
T14	1280x960	60
T15	1280x960	85
T16	1280x1024	60
T17	1280x1024	75
T18	1280x1024	85
T19	1600x1200	60
T20	1920x1200	60
T21	720x480i	59
T22	720x480i	60
T23	720x480p	59
T24	720x480p	60
T25	1280x720p	59
T26	1280x720p	60
T27	1920x1080i	59
T28	1920x1080i	60
T29	1920x1080p	59
T30	1920x1080p	60
T31	720x576i	50
T32	720x576p	50
T33	1280x720p	50
T34	1920x1080i	50
T35	1920x1080p	50
T36	1920x1080p	23
T37	1920x1080p	24
T38	1366x768	60
T39	1366x768	50

No.	Signal Content	Description
P01	PURITY	Purity pattern Purity offers eight different full field patterns: Black, White (100% Y)
P02	PURITY	Primary colors: Red, Green, Blue Complementary colors: Magenta, Yellow, Cyan
P03	PURITY	P01: White
P04	PURITY	P02: Blue P03: Red
P05	PURITY	P04: Magenta P05: Green
P06	PURITY	P06: Cyan P07: Yellow
P07	PURITY	P08: Black
P08	PURITY	

Application

1. The red and green patterns are most frequently used for checking color purity. The red pattern is selected only this color should be visible; the presence of any other color is an indication that color purity needs adjustment.
2. The green pattern provides a purity check for three in-line tubes. In the in-line tubes, the guns are in a horizontal position and the green gun is located in the center.
3. The blue is the complementary colors are often used to check the color performance.
4. The red are used to ensure that there is no interference between the sound and chroma carrier. Furthermore the red pattern is used to adjust the longplay delay level to minimum flicker.
5. In addition to the primary and complementary colors 100% white can be selected as well as black pattern with color burst to check.

P09		Gradual pattern Gradual transition of colors.
P10		
P11		
P12		





Application

This pattern is for brightness control and luminance writing current. And this can overall the color performance, amplitude response/resolution and linearity of chroma amplitude.

P13		Color Bar Comprises 8 vertical bars- White, Yellow, Cyan, Green, Magenta, Red, Blue and Black
-----	---	---



Application

The white bar, to adjust the amplitude of the color difference signals with respect to the luminance signal on the picture tube. The blue and green guns can be switched off to allow the amplitude of the R-Y signal to be adjusted. This is done by ensuring that no difference in brightness is observed between vertical bars five and six of the color bar and the horizontal reference bar. In a similar fashion, the amplitude of the B-Y demodulator can be determined.

P14		Grayscale Full screen linear staircase signal with 8/16/32/64 identical steps from black to white
P15		
P16		
P17		



Application

This is used to locate faulty linearity of the video amplifier or greyscale setting. Nonlinearities mainly result in a compression of the white level.

P18		Black-White Vertical Full screen linear vertical bar signal with black/white intervals of 1/6/12 pixels.
P19		
P20		



Application

This pattern serves for a quick check of color monitor's horizontal bandwidth and phase behavior of a video transmission. Also, verify video amplifier and color temperature.

P21		Black-White Horizontal Full screen linear Horizontal bar signal with black/white intervals of 1/3/6 pixels.
P22		
P23		





Application

This pattern serves for a quick check of color monitor's vertical bandwidth and phase behavior of a video transmission. Also, verify video amplifier and color temperature.

P24		Multi-burst Full screen definition pattern of frequencies 0.5, 1.0, 2.0, 4.0, 4.8, and 5.8 MHz for 625 line systems.	-Video bandwidth -Check luminance amplifier in B/W -Amplitude response/ resolution -Check resolution of monitors and video recorders -Measure the frequency amplitude response
P25			

Application

The pattern checks the bandwidth of the video or luminance amplifier in B/W or CTVs as well as the resolution of monitors and video recorders. It can also be used to check or measure the frequency amplitude response.

P26		Grid Full screen grid with black/white intervals of 1/3/6/12 pixels. P26: 1 pixel P27: 3 pixels P28: 6 pixels P29: 12 pixels
P27		
P28		
P29		

Application

This pattern is mainly used for checking and aligning dynamic and corner convergence of TVs or monitors.

P30		Running H Full screen filled with lines of H characters, a new line of H will run from upper left corner and fill down when a line is completed.
-----	---	--

Application

This is the special test for test/video motion verification and refreshing rate.

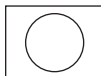
P31		Circle Black circles on white background, 640x480 has 4 by 3 total 12 circles, 800x600 has 5 by 3 total 15 circles, 1024x768 has 6 by 4 total 24 circles,
-----	---	---

Application

It's suited for checking the overall linearity and geometry of the screen of a monitor or TV.

P32		Black/White Up/Down Full screen filled with upper half of 100% white and lower half of 100% black.
-----	---	--

Application

This pattern is for brightness control and purity checking. Also, to do the white setting and synchronization.

P33	CYP	Cypress Patterns Cypress specifically designed patterns. P33: Greyscale P34: 3 step Horizontal color bar P35: SMPTEbar P36: CYP-4 P37: Britebox-1 P38: EDID
P34	CYP	
P35	CYP	
P36	CYP	
P37	CYP	
P38	EDID	

Application

P33: This pattern is used for a reflection check or for adjusting the VCR video demodulator to a symmetrical black and white jump or opposite.
P34: This pattern serves for a quick check of color monitor.
P35,P36: This pattern can be used to check the video handling capabilities of most parts of a television system.
P37: The wrong brightness setting on the monitor may cause other tests such as Contrast, Focus and Beam Size to be invalid.
P38: Reading EDID.

P39	HDCP	HDCP-Produce Green/Blue horizontal bars with HDCP verification and data comparison on the upper first third area of black background
-----	-------------	--

Application

To test DVI and HDMI receivers with HDCP. All DVI and HDMI options, including analyzer options, support HDCP production keys if the HDCP option is installed.

6. Remote Control

1. Switch to P39 HDCP
2. Turn on/off AUTO pattern random-cycling
3. Color Space Selection:
RGB 4:4:4
YUV 4:4:4
YUV 4:2:2
4. Audio Output Selection:
External L/R
External Optical
Internal Shinewave
5. HDMI/DVI Output Selection
6. Quick TIMING Selection:
VGA - T01 640x480-60
SVGA - T06 800x600-60
XGA - T10 1024x768-60
SXGA - T16 1280x1024-60
UXGA - T19 1600x1200-60
1080i - T27 1920x1080i-59
480p - T23 720x480p-59
720p - T25 1280x720p-59
1080p - T29 1920x1080p-59
7. Sampling Rate (-)
Sampling Rate (+)
192 KHz
96 KHz
48 KHz
44K1Hz
32 KHz
8. [pqtu]
UP/DOWN: TIMING (+) (-)
RIGHT/LEFT: PATTERN (+) (-)
9. A/V Mute ON
10. A/V Mute OFF
11. Confirm OK

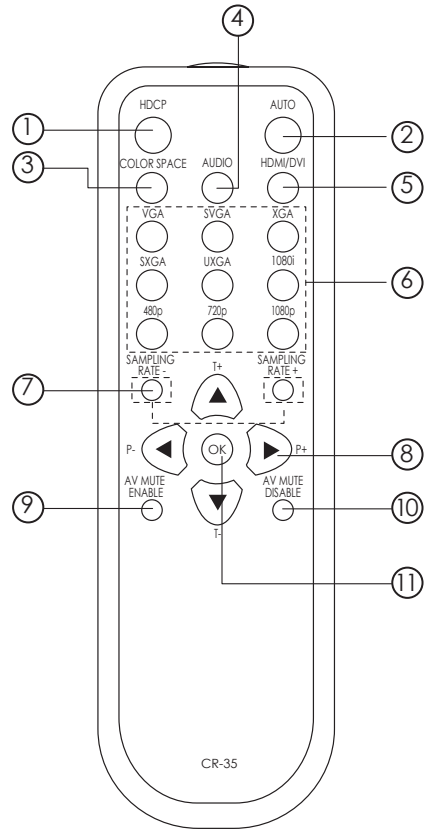

7. RS-232 Remote Control Protocol

* The connection between the system and remote controller with **RS-232 modem cable**.

Pins definition of modem cable

System			Remote Controller	
PIN	Definition		PIN	Definition
1	NC		1	NC
2	TxD		2	RxD
3	RxD		3	TxD
4	NC		4	NC
5	GND		5	GND
6	NC		6	NC
7	NC		7	NC
8	NC		8	NC
9	NC		9	NC

* RS-232 transmission format:

Baud Rate : 19200 bps

Data Bit : 8 bits

Parity : None

Stop Bit : 1 bit

* Command

Function	Command Code	CPHD-1 Reply	
Test connection			
	URTCNT+SPACE+0+SPACE+'A'+D'		OK
Timing Selection			
	1. TMIX+SPACE+1+SPACE+'A'+D'		OK
	2 SPACE+ timingindex +SPACE		OK
Pattern Selection			
	1.PTIX+SPACE+1+SPACE+'A'+D'		OK
	2 SPACE+ patternindex +SPACE		OK

Timing index 1	640x480-60	Pattern Index 1	White
Timing index 2	640x480-72	Pattern Index 2	Blue
Timing index 3	640x480-75	Pattern Index 3	Red
Timing index 4	640x480-85	Pattern Index 4	Magenta
Timing index 5	800x600-56	Pattern Index 5	Green
Timing index 6	800x600-60	Pattern Index 6	Cyan
Timing index 7	800x600-72	Pattern Index 7	Yellow
Timing index 8	800x600-75	Pattern Index 8	Black
Timing index 9	800x600-85	Pattern Index 9	Gradually Red
Timing index 10	1024x768-60	Pattern Index 10	Gradually Green
Timing index 11	1024x768-70	Pattern Index 11	Gradually Blue
Timing index 12	1024x768-75	Pattern Index 12	Gradually Gray
Timing index 13	1024x768-85	Pattern Index 13	Color Bar
Timing index 14	1280x960-60	Pattern Index 14	Gray-8
Timing index 15	1280x960-85	Pattern Index 15	Gray-16
Timing index 16	1280x1024-60	Pattern Index 16	Gray-32
Timing index 17	1280x1024-75	Pattern Index 17	Gray-64
Timing index 18	1280x1024-85	Pattern Index 18	BW-1
Timing index 19	1600x1200-60	Pattern Index 19	BW-6
Timing index 20	1920x1200-60	Pattern Index 20	BW-12
Timing index 21	720x480i-59	Pattern Index 21	Hor-1
Timing index 22	720x480i-60	Pattern Index 22	Hor-3
Timing index 23	720x480P-59	Pattern Index 23	Hor-6
Timing index 24	720x480P-60	Pattern Index 24	Multibust-1
Timing index 25	1280x720P-59	Pattern Index 25	Multibust-2
Timing index 26	1280x720P-60	Pattern Index 26	Grid-1
Timing index 27	1920x1080i-59	Pattern Index 27	Grid-3
Timing index 28	1920x1080i-60	Pattern Index 28	Grid-6
Timing index 29	1920x1080P-59	Pattern Index 29	Grid-12
Timing index 30	1920x1080P-60	Pattern Index 30	Running-H
Timing index 31	720x576i-50	Pattern Index 31	Circles
Timing index 32	720x576P-50	Pattern Index 32	BW_Upper_Down
Timing index 33	1280x720P-50	Pattern Index 33	CYP_1
Timing index 34	1920x1080i-50	Pattern Index 34	CYP_2
Timing index 35	1920x1080P-50	Pattern Index 35	CYP_3
Timing index 36	1920x1080P-23	Pattern Index 36	CYP_4
Timing index 37	1920x1080P-24	Pattern Index 37	CYP_5
Timing index 38	1366x768-60	Pattern Index 38	EDID
Timing index 39	1366x768-50	Pattern Index 39	HDCP_Produce

SPACE = ASCII(32)

1 = ASCII(1)

PatternIndex = ASCII(PatternIndex)

8. RS232 Remote Control Application

8.1 Main Window

Double-click the executable exe file to launch the application, the main window will show up.

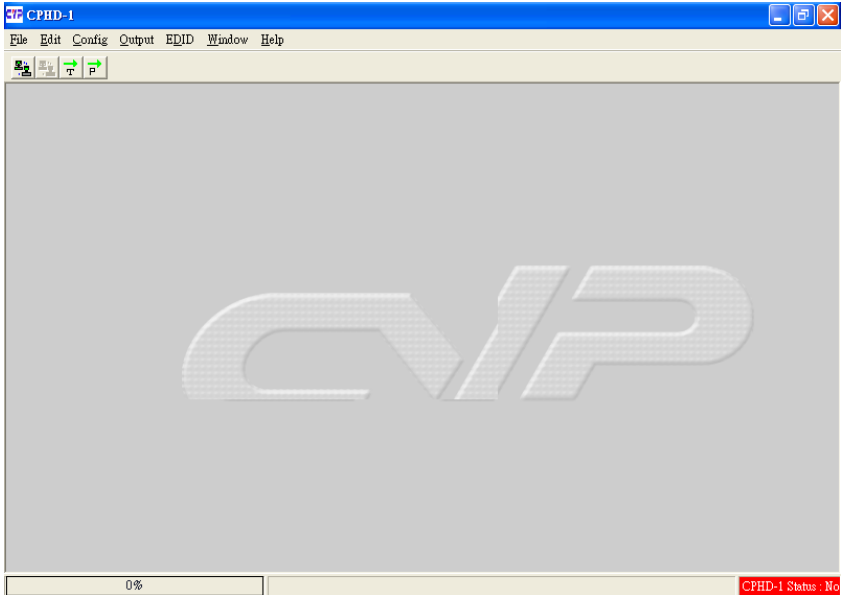

IMPORTANT: When the right hand bottom shows warning message 'CPHD-1 Status: Not Exit, clicking the Connect  button to link to the unit.

8.2 Select COM port to control

Click and select the [COM port] from [Config] option of the tool bar to launch the Program window. There are 8 different COM ports can choose. After the port been selected click [OK] to confirm the control port.

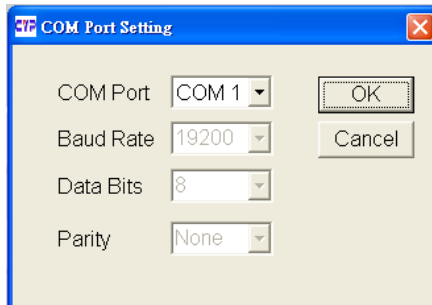

8.3 Switch TIMING

Click and select the [Timing] from [Output] option of the tool bar to launch the Program window.

Click [Show List] to display each timing's Horizontal/Vertical/Pixel Clock.

Click [Run Timing] button to start the output of selected timing.

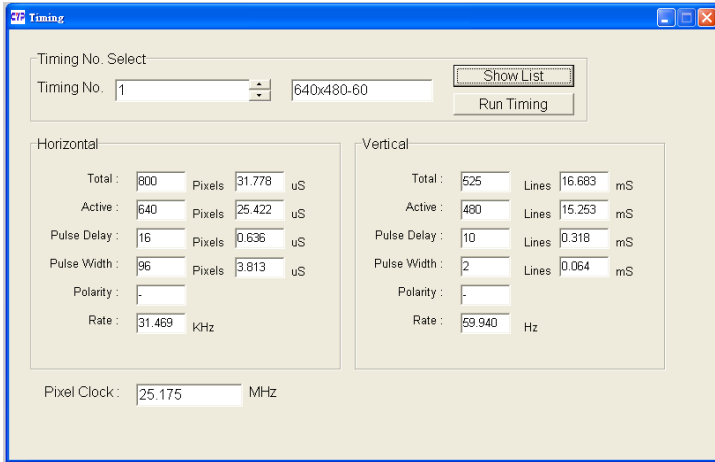

List of Timings

Timing Name	Pixel Rate	Horizontal	Vertical
640x480-60	25.175 MHz	31.469 KHz	59.940 Hz
640x480-72	31.500 MHz	37.861 KHz	72.809 Hz
640x480-75	31.500 MHz	37.500 KHz	75.000 Hz
640x480-85	36.000 MHz	43.269 KHz	85.008 Hz
800x600-56	36.000 MHz	35.156 KHz	56.250 Hz
800x600-60	40.000 MHz	37.879 KHz	60.317 Hz
800x600-72	50.000 MHz	48.077 KHz	72.188 Hz
800x600-75	49.500 MHz	46.875 KHz	75.000 Hz
800x600-85	56.250 MHz	53.674 KHz	85.061 Hz
1024x768-60	65.000 MHz	48.363 KHz	60.004 Hz
1024x768-70	75.000 MHz	56.476 KHz	70.069 Hz
1024x768-75	78.750 MHz	60.023 KHz	75.029 Hz
1024x768-85	94.500 MHz	68.677 KHz	84.997 Hz

8.4 Switch PATTERN

Click and select the [Pattern] from [Output] option of the tool bar to launch the Program window.

Click [Show List] to select output pattern and then click [Run Pattern] button to start the output of selected pattern.

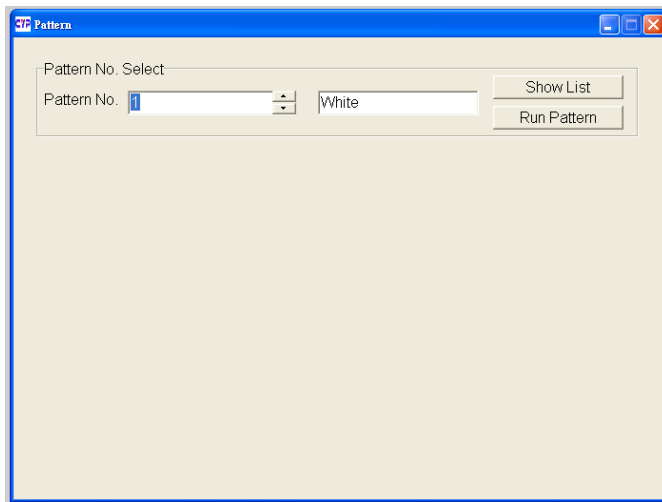

List of Patterns



Pattern NO.	Pattern Name
1	White
2	Blue
3	Red
4	Magenta
5	Green
6	Cyan
7	Yellow
8	Black
9	Gradually Red
10	Gradually Green
11	Gradually Blue
12	Gradually Gray
13	Color Bar
14	Gray-8

8.5 Programming TIMING/PATTERN

Click and select the [Program] from [Edit] option of the tool bar to launch the Program window.

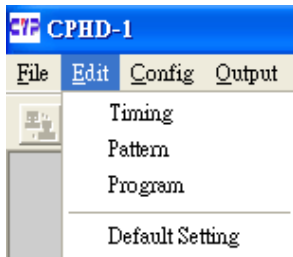

Program the desired sequence of timing/pattern/unit/show time, then click [Upload] to send the program to the unit.

IMPORTANT: For every timing pattern have to shown at least 3 seconds.

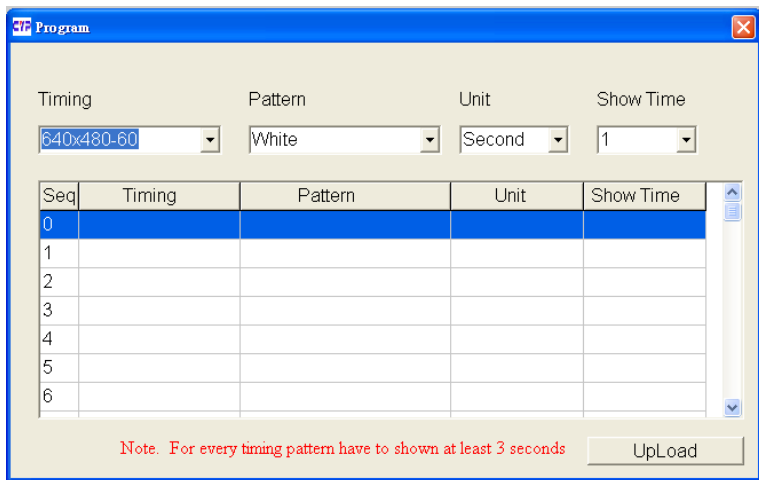

Click and select the [Save as] from [File] option of the tool bar to save your settings.

Click the [Open] from [File] option of the tool bar to load the saved data.

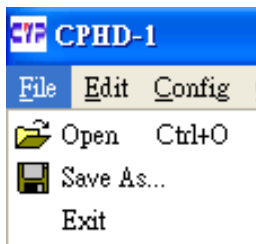

Click and select the [Timing] from [Edit] option of the tool bar to launch the Program window.

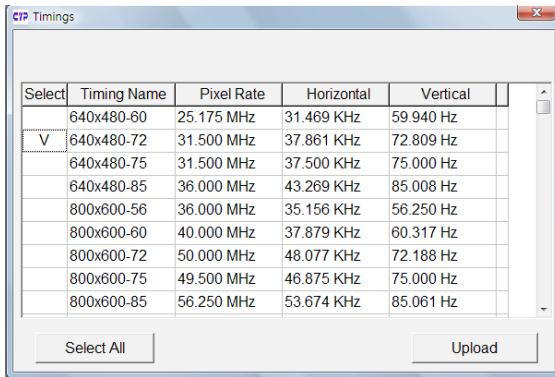

Program the desired timings, and then click [Upload] to send the program to the unit.

Click and select the [Pattern] from [Edit] option of the tool bar to launch the Program window.

Program the desired patterns and then click [Upload] to send the program to the unit.

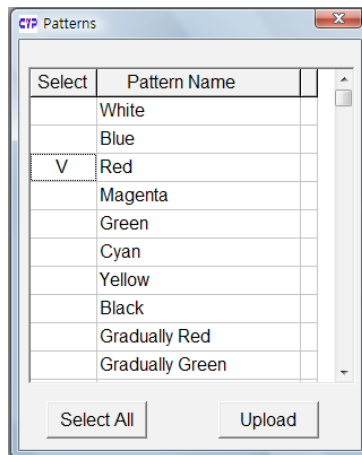

Click and select the [Default Setting] from [Edit] option of the tool bar to reset the unit to factory setting.

8.6 EDID

8.6.1 Read EDID

Click and select the [Read EDID] from [EDID] option of the tool bar to read out the EDID from the display source (e.g. LCD TV). Meanwhile, click and select the [Save as] from [File] option of the tool bar to save the EDID information to the computer in .bin format (e.g. to save as this file format "cypress.bin").

8.6.2 Memory of EDID

When click and select the [Memory] from [EDID] to read out the data, but the user may not know the data information that read out from the source. The user can use "Explore Semiconductor EDID Editor" to read out the EDID information.

From "Explore Semiconductor EDID Editor", click the [Open] from [File] option of the tool bar to read out the EDID data.

8.6.3 Upload EDID

Click the [Open] from [File] option of the tool bar to load the saved data (e.g. cypress.bin).

Click and select the [Upload EDID] from [EDID] option of the tool bar to write the EDID to the unit.

IMPORTANT: After upload EDID to the unit, don't operation this unit before write EDID to the display unit. Otherwise, the EDID data will lose due to the memory size problem.

8.6.4 Write EDID

Click and select the [Write EDID] from [EDID] option of the tool bar to write the EDID to the display unit.



CYPRESS TECHNOLOGY CO., LTD.
Home page: <http://www.cypress.com.tw>

20070802 MPM-CPHD1